



TE-NE, 20 – 105 VA 230 – 240/12 V 0/50/60 Hz
Dimming via trailing-edge phase dimmer

Product description

- Short-circuit shutdown feature with automatic restart
- For emergency lighting systems as per EN 50172
- Overtemperature and overload protection by reducing power and automatic restart
- Screw terminal
- Not suitable for operation with MR16 LED bulbs

Technical data

Protection class	II
Mains frequency	0 / 50 / 60 Hz
Efficiency	> 94 %
λ	> 0.95
Max. cable length secondary	2 m

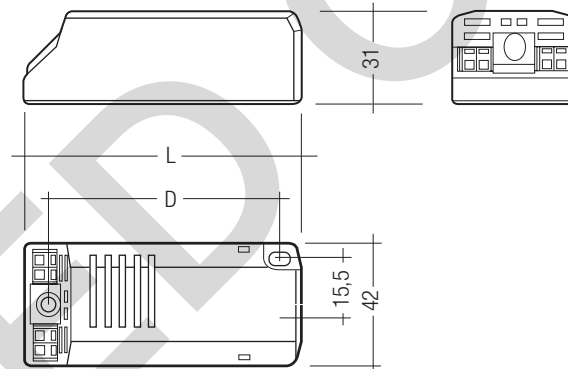
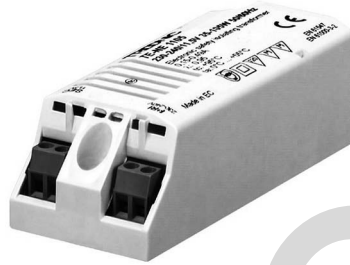

Ordering data

Lamp wattage	Dimensions LxWxH	Distance between mounting holes (D)	Dimming	Type	Article number
20 – 70 VA	102 x 42 x 31 mm	86 – 88 mm	Trailing-edge phase control	TE-NE 1070	22082145
35 – 105 VA	102 x 42 x 31 mm	86 – 88 mm	Trailing-edge phase control	TE-NE 1105	22082139

Packaging: 20 pieces/carton, 1400 pieces/pallet

Specific technical data

Type	Rated supply voltage AC	Rated supply voltage DC	Rated current (at 230 V 50 Hz)	Secondary voltage 230 V	DC lamp output	Operating frequency	Ambient temperature t_a	Max. casing temperature	Soft-start	Weight
TE-NE 1070	230 – 240 V	220 – 240 V	0.32 A	11.25 V	< 70 %	35 kHz	0 ... +65 °C	90 °C	yes	0.13 kg
TE-NE 1105	230 – 240 V	220 – 240 V	0.48 A	11.25 V	< 70 %	35 kHz	0 ... +55 °C	85 °C	yes	0.15 kg